



**SWISS
TECHNOLOGY
PRODUCTION**

Swiss Technology Production SA

Rue des Places 13

CH-2855 Glovelier, Switzerland

Phone +41 32 427 01 00

www.swisstp.com

info@swisstp.com

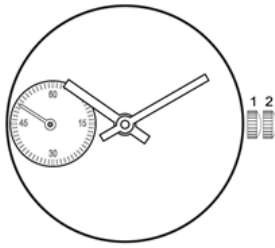

STP2-12-12

Specifications techniques - Technische Spezifikationen - Technical specifications

Données indicatives, Richtwerte, Recommended values

Forme et genre Form und Art Shape and type	Calibre rond, échappement à ancre, mouvement mécanique automatique Rundes Kaliber, mechanisches Ankerwerk, autom. Aufzug Round caliber, mechanical lever movement, self winding		
Fréquence Frequenz Frequency	28'800 alternances par heures (4Hz) 28'800 Halbschwingungen pro Stunde (4Hz) 28'800 vibrations per hour (4Hz)		
Empierrage Steine Jewelling	34 jewels		
Diamètre total Gesamtdurchmesser Overall diameter	26.20 mm		
Diamètre d'encageage Gehäusepassungsdurchmesser Case fitting diameter	25.60 mm		
Hauteur Höhe Height	6.20 mm		
Fonctions Funktionen Functions	Heures, Minutes, petite seconde à 9h Stunden, Minuten, kleine Sekunde auf 9h Hours, Minutes, small second at 9h		
Mise à l'heure, Tige de remontoir Zeiteinstellung, Aufzugswelle Time setting, Winding system	2 positions: 1) position de remontage, 2) mise à l'heure, stop seconde. Voir mode d'emploi 2 Positionen: 1) Handaufzug, 2) Zeiteinstellung, stop Sekunde. Beachten Sie Gebrauchsanweisung für weitere Hinweise 2 positions: 1) Manual winding, 2) Time setting, stop second. Please consult manual for additional important information.		
Tige de remontoir, longuer standard Aufzugswelle, Standardlänge Winding stem, standard length	15.7 mm	extra longuer Extra Länge oversize length	17.7 mm
Stop secondes Sekundenstopp Stop seconds	avec mit with		

Sous réserve de toute modification sans préavis - All modifications reserved without notice - Änderungen ohne Voravis vorbehalten

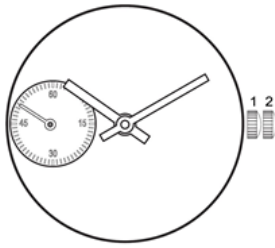

STP2-12-12

Specifications techniques - Technische Spezifikationen - Technical specifications

Données indicatives, Richtwerte, Recommended values

Ressort de barillet Zugfeder Barrel spring	Nivaflex NM
Moment de force Kraftmoment Moment of force	M0,5 1090 - 1130 gmm M24min 869gmm
Moment de glissement Gleitmoment Sliding moment	Min: 1250 gmm Max: 1575 gmm
Réserve de marche Gangreserve Power reserve	42 heures/Stunden/hours
Positions de contrôle Lagenkontrolle Positions of testing	(Critères COSC) (COSC Kriterien) (COSC criteria) 5 positions, CH, CB, 6H, 9H, 3H
Marche moyenne (0H) Max Abweichung (0H) Average rate (0H)	-0/+15 sec/d
Amplitude max. (CH-0H) Max. Schwingungsweite (CH-0H) Max amplitude (CH-0H)	320°
Amplitude min. (6H-24H) Min. Schwingungsweite (6H-24 H) Min. amplitude (6H-24H)	200°
Temps de stabilisation Stabilisationszeit Stabilisation time	20 s
Temps de mesure Messungszeit Measuring time	40 s
Amortisseurs de chocs Stossdämpfer Shock absorber	Incabloc
Balancier Unruh Balance wheel	doré vergoldet gilt
Angle de levé Hebungswinkel Lift angle	52°
Ecart max. toutes positions Max Abweichung alle Lagen Max variation all positions	15 s
Isochronisme (CH 0H - CH 24H) Isochronismus (CH 0H - CH 24H) Isochronism (CH 0H - CH 24H)	± 20 s/d

Sous réserve de toute modification sans préavis - All modifications reserved without notice - Änderungen ohne Voravis vorbehalten

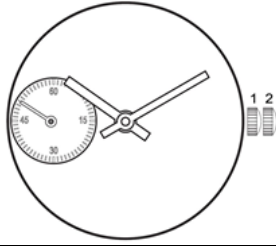

STP2-12-12

Complément d'information - Ergänzung information - Extra information

- 1) Les valeurs limites sont sujettes à interprétation: 95 % des pièces livrées par lot doivent se situer dans les marges indiquées.
Die Grenzwerte sind eine Frage der Auslegung: 95 % der in einer Lieferung enthaltenen Stücke müssen innerhalb der angegebenen Limiten liegen. The limit values are subject to interpretation: 95 % of the pieces delivered in a lot must be within the specified limits.
- 2) Toutes les mesures se font sans calendrier en prise et chrono non embrayé. Les contrôles à armage haut, désignés par 0 h, se font entre 1 et 3 heures après armage complet.
Für die Messungen darf sich der Kalender nicht im Eingriff befinden und der Chrono muss ausgekuppelt sein.
Die Kontrolle bei Vollaufzug, angegeben mit 0 h, wird 1 bis 3 Stunden nach dem Aufziehen gemacht.
All check are made without the calendar in function and chrono not coupled. The check has to be done at full winding, referred to as 0 h, after 1 to 3 hours running.
- 3) Lors du contrôle des marches instantanées et des amplitudes, il faut impérativement tenir compte des imprécisions de mesure dues aux appareils, à la température et à la pression atmosphérique agissant sur les réglages.
Im Weiteren muss bei einer augenblicklichen Gang- und Schwingungsweitekontrolle unbedingt die momentane Einwirkung der Apparate bzw. der Raumtemperatur und des Atmosphärendrucks einbezogen werden.
When checking the instantaneous rate and the amplitudes, the inherent tolerance of the measuring instruments and the influence of temperature variations and the atmospheric pressure must be taken into account.

Remontage - Aufzug - Winding

Par la tige de remontoir:

Nombre de tours mini.: 27
A l'aide d'un moteur:
- dispositif automatique monté:
vitesse max.: 100 t/min
temps max.: 25 s
- dispositif automatique non monté:
vitesse max.: 400 t/min
temps max.: 10 s

Über die Aufzugswelle:

Umdrehungen mini.: 27
Mit Hilfe eines Aufzugmotors:
- Automatik-Mechanismus montiert:
Geschwindigkeit max.: 100 U/min
Zeit max.: 25 s
- Automatik-Mechanismus nicht montiert:
Geschwindigkeit max.: 400 U/min
Zeit max.: 10 s

With winding stem

Turns mini.: 27
With help of motor:
- self-winding mechanism assembled:
speed max.: 100 t/min
time max.: 25 s
- self-winding mechanism not assembled:
speed max.: 400 t/min
time max.: 10 s

Par le dispositif automatique:

Sur machine Chapuis
(mouvement en marche) : 1 h 30
(Rotation 16 cycles/min)
Sur Cyclotest (mouvement arrêté,
tige tirée) : 1250 tours
(Rotation 4 t/min)

Über den automatischen Aufzug:

Auf Chapuis-Maschine
(Werk in Betrieb): 1 h 30
(Drehgeschwindigkeit 16 Zyklen/min)
Auf Cyclotest (Werk ausser Betrieb,
Stellwelle gezogen): 1250 Umdrehungen
(Drehgeschwindigkeit 4 U/min)

With the self winding:

On Chapuis apparatus
(movement in motion): 1 h 30
(Rotation 16 cycles/min)
On Cyclotest (stopped movement,
stem pulled out) : 1250 turns
(Rotation 4 t/min)

Module additionnel STP2-12/D012

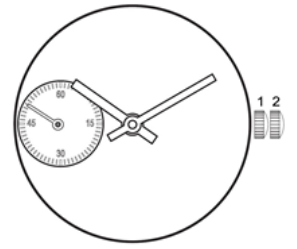

Caractéristiques techniques principales

Mouvement automatique:	STP1-11, rond
Fréquence:	28'800 alternances par heures [4 Hz]
Nombre de rubis mouvement:	28
Module additionnel:	D012
Diamètre total:	ø26.20 mm
Diamètre d'encageage:	ø25.60 mm
Hauteur total:	6.20 mm (module assemblé sur mouvement automatique, sans l'aiguillage)
Nombre de rubis du module:	8
Affichage:	Affichage par aiguilles au centre Heures, Minutes Affichage par aiguille à 9h Petite seconde

Tige de remontaire:	1) Remontage manuel 2) Mise à l'heure
---------------------	--

Mode d'emploi: Remontage automatique de la montre par les mouvements du poignet.
Couronne avec 2 positions:
1) Position normale (Position de remontage)
2) Mise à l'heure (Stop seconde)

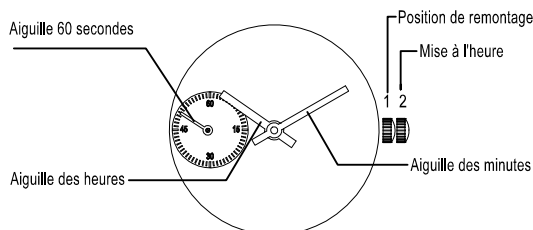

Sous réserve de toute modification sans préavis - tous droits réservés

STP Swiss Technology Production SA
Rue des Places 13
CH-2855 Glovelier / Switzerland
Phone +41 32 427 01 00
www.swisstp.com



Caliber: STP2-12-12

Created: 08.02.2019

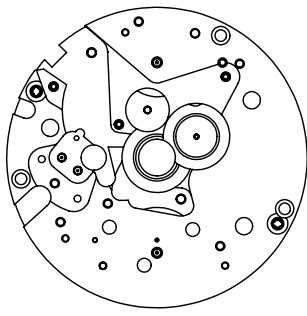

7164232

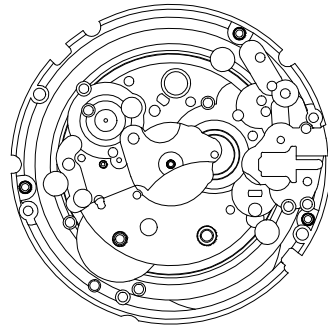

7164231

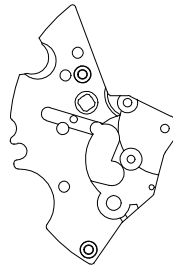

7164233

(Ech 1.5:1)

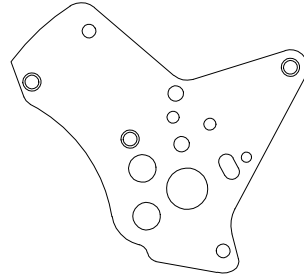

7164236

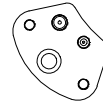

7164237

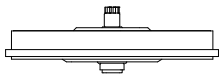

7171918

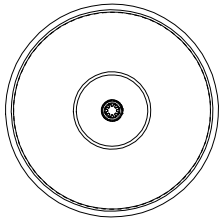

7164217



7164218



7164219



7164220



7164207

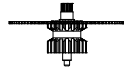

7164221

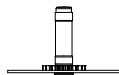

7164209



7120681

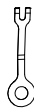

7164229

(Ech 2:1)



7164238



7015079









7015077



7349588

(Ech 5:1)

Montage modifications sur Calibre STP1-11

-  Huile Moebius 9010
-  Jismaa 124 Blue
-  Huile Moebius HP1300
-  9415
-  Ne pas lubrifier
-  Très faible quantité
Huile Moebius 9010

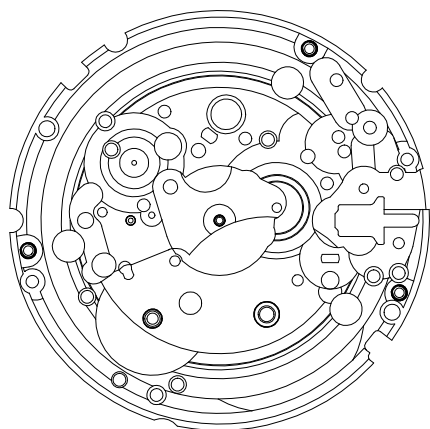
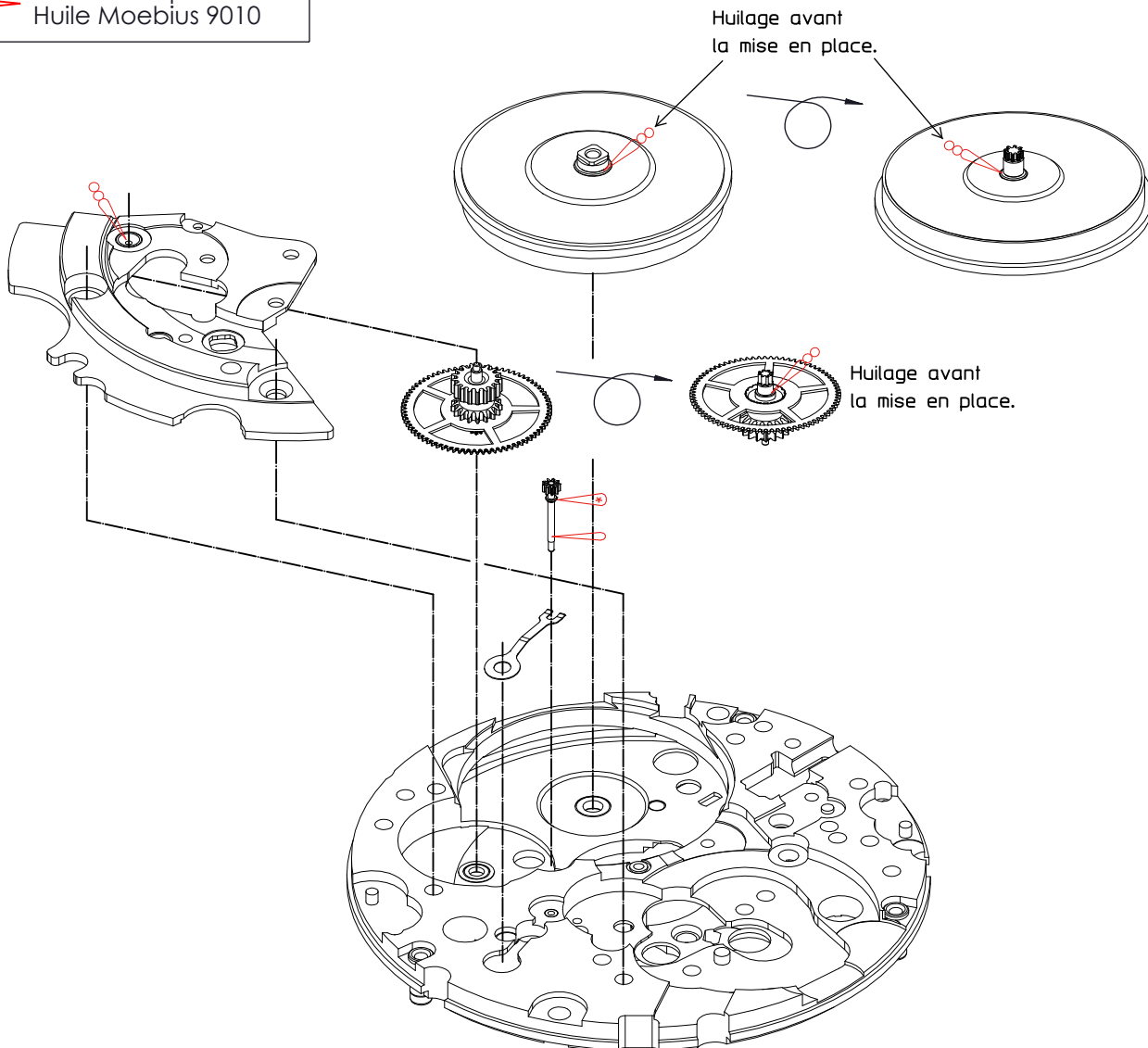

7164231

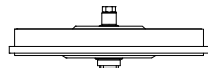

7171918

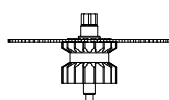

7164221

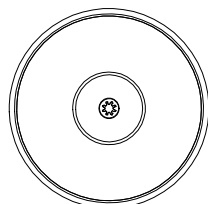

7164218

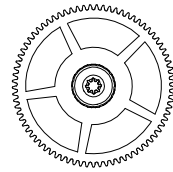



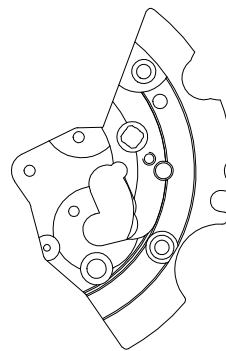



7164233



7164229

Nous nous réservons tous les droits sur ce document. Il est confié au destinataire. Il ne peut, sans notre autorisation écrite, être copié, reproduit, communiqué à des tiers.
 Für dieses Dokument behalten wir uns alle Rechte vor. Es ist nur für den Empfänger bestimmt. Ohne unsere schriftliche Bewilligung darf es nicht kopiert, vervielfältigt und Dritten zugänglich gemacht werden.
 We reserve all rights for this document. It is meant for the recipient only and it may not be copied, printed or given to a third person without our written permission.

Montage modifications sur Calibre STP1-11

-  Huile Moebius 9010
-  Jismaa 124 Blue
-  Huile Moebius HP1300
-  9415
-  Ne pas lubrifier
-  Très faible quantité
Huile Moebius 9010

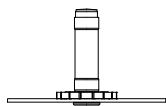
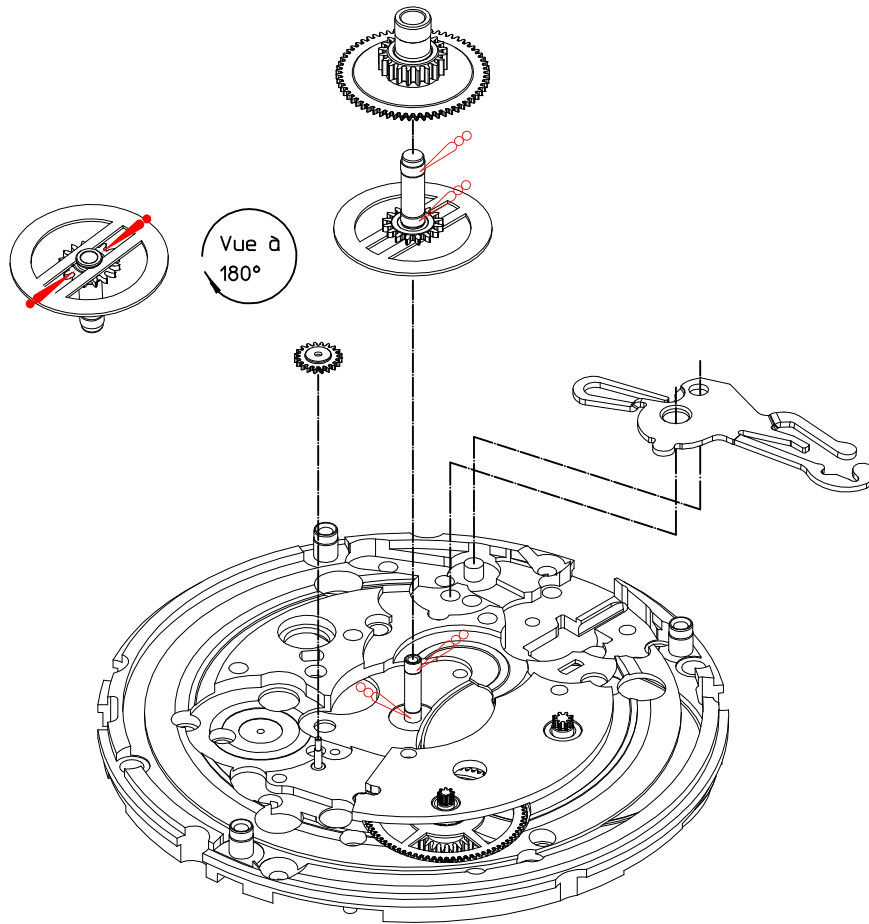

7164209

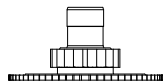





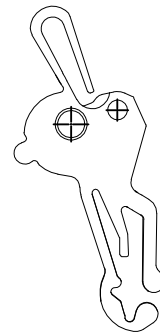

7164207



7164217



7120681

-  Huile Moebius 9010
-  Jismaa 124 Blue
-  Huile Moebius HP1300
-  9415
-  Ne pas lubrifier
-  Très faible quantité
Huile Moebius 9010

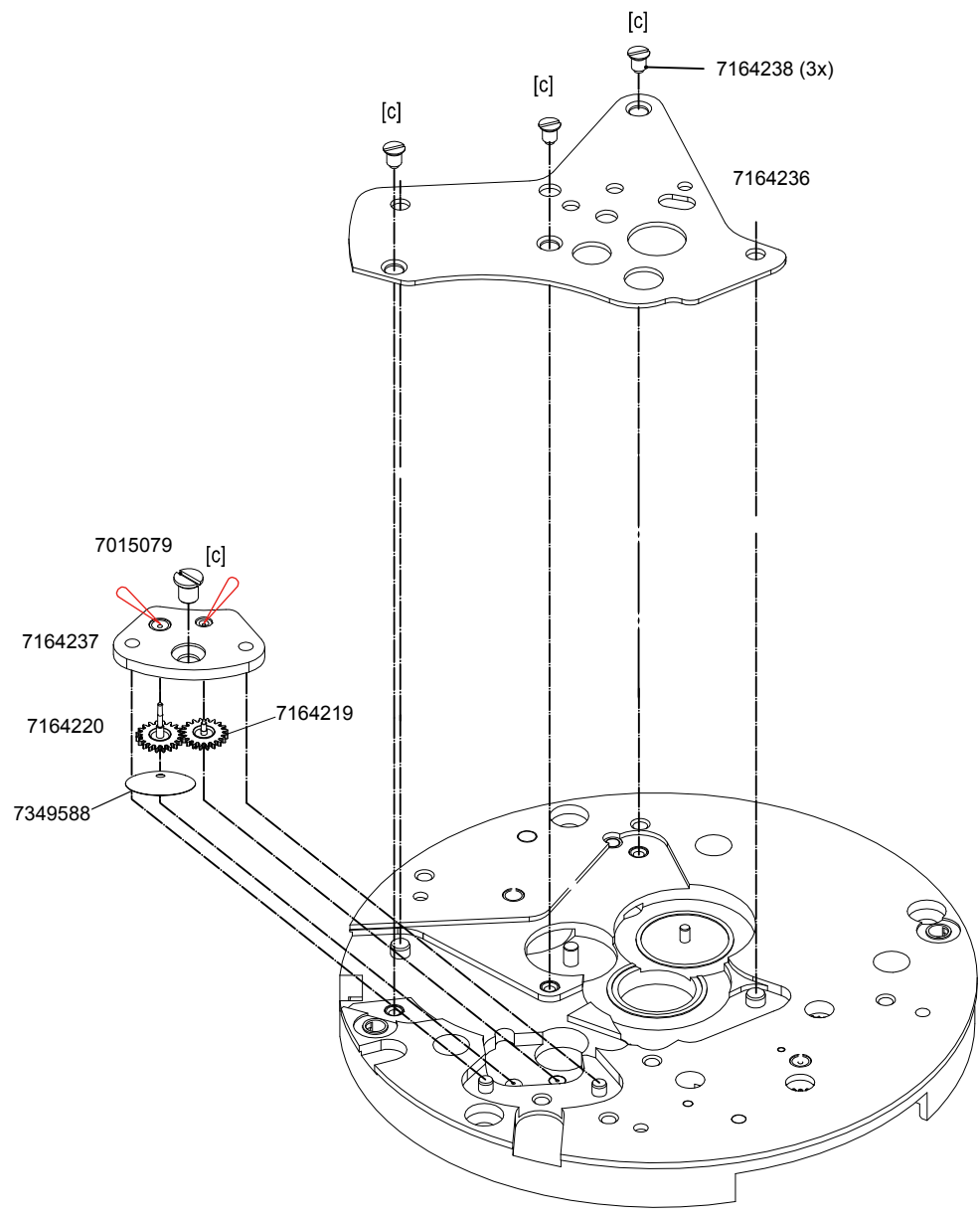

Couple minimum de dévissage	
[a]	1.8Ncm
[b]	1.6Ncm
[c]	1.2Ncm
[d]	0.8Ncm
[e]	0.6Ncm

Nous nous réservons tous les droits sur ce document. Il ne peut, sans notre autorisation écrite, être copié, reproduit, communiqué à des tiers.
 Für dieses Dokument behalten wir uns alle Rechte vor. Es ist nur für den Empfänger bestimmt. Ohne unsere schriftliche Bewilligung darf es nicht kopiert, vervielfältigt und Dritten zugänglich gemacht werden.
 We reserve all rights for this document. It is meant for the recipient only and it may not be copied, printed or given to a third person without our written permission.







STP Swiss Technology Production SA
 Rue des Places 13
 CH-2855 Glovelier / Switzerland
 Phone +41 32 427 01 00
 www.swisstp.com



Caliber: STP2-12-12

Created: 13.02.2019

Page:6/8

-  Huile Moebius 9010
-  Jismaa 124 Blue
-  Huile Moebius HP1300
-  9415
-  Ne pas lubrifier
-  Très faible quantité
Huile Moebius 9010

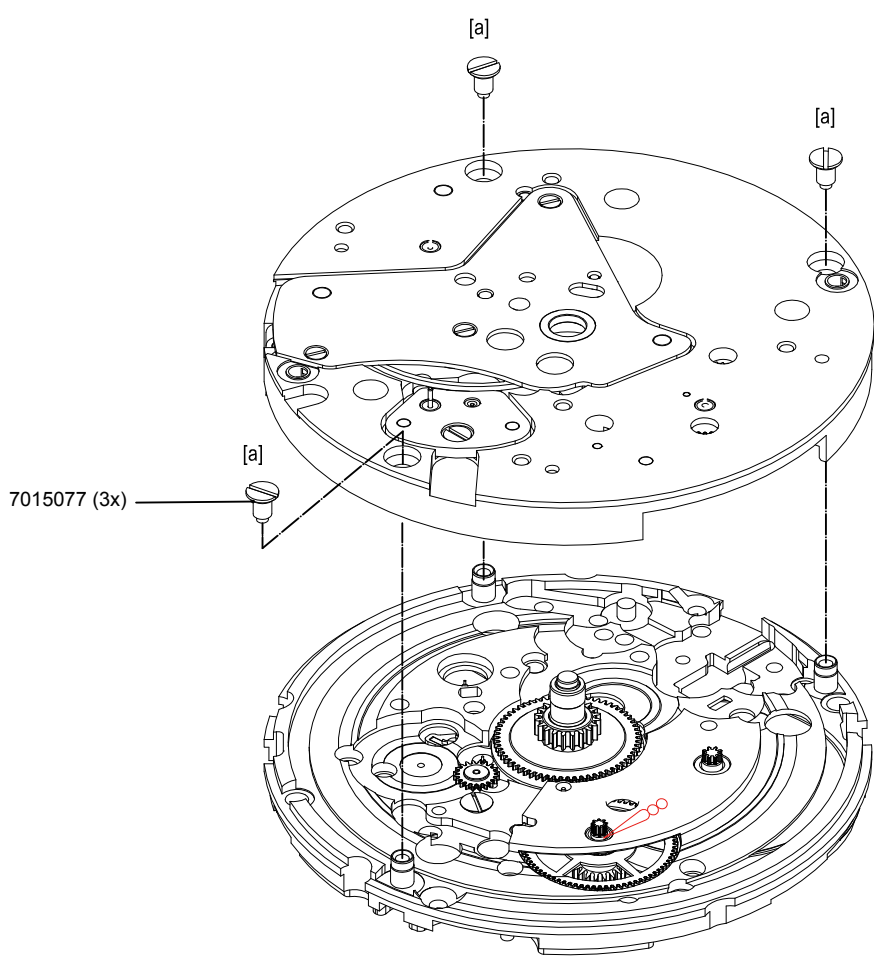

Couple minimum de dévissage
[a] 1.8Ncm
[b] 1.6Ncm
[c] 1.2Ncm
[d] 0.8Ncm
[e] 0.6Ncm

Nous nous réservons tous les droits sur ce document. Il est confié au destinataire. Il ne peut, sans notre autorisation écrite, être copié, reproduit, communiqué à des tiers.
 Für dieses Dokument behalten wir uns alle Rechte vor. Es ist nur für den Empfänger bestimmt. Ohne unsere schriftliche Bewilligung darf es nicht kopiert, vervielfältigt und Dritten zugänglich gemacht werden.
 We reserve all rights for this document. It is meant for the recipient only and it may not be copied, printed or given to a third person without our written permission.

STP Swiss Technology Production SA
 Rue des Places 13
 CH-2855 Grenchen / Switzerland
 Phone +41 32 427 01 00
 www.swisstp.com

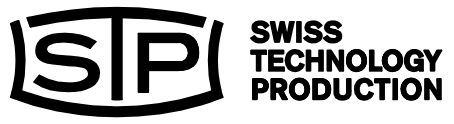

Caliber: STP2-12-12

Created: 13.02.2019 Page:7/8

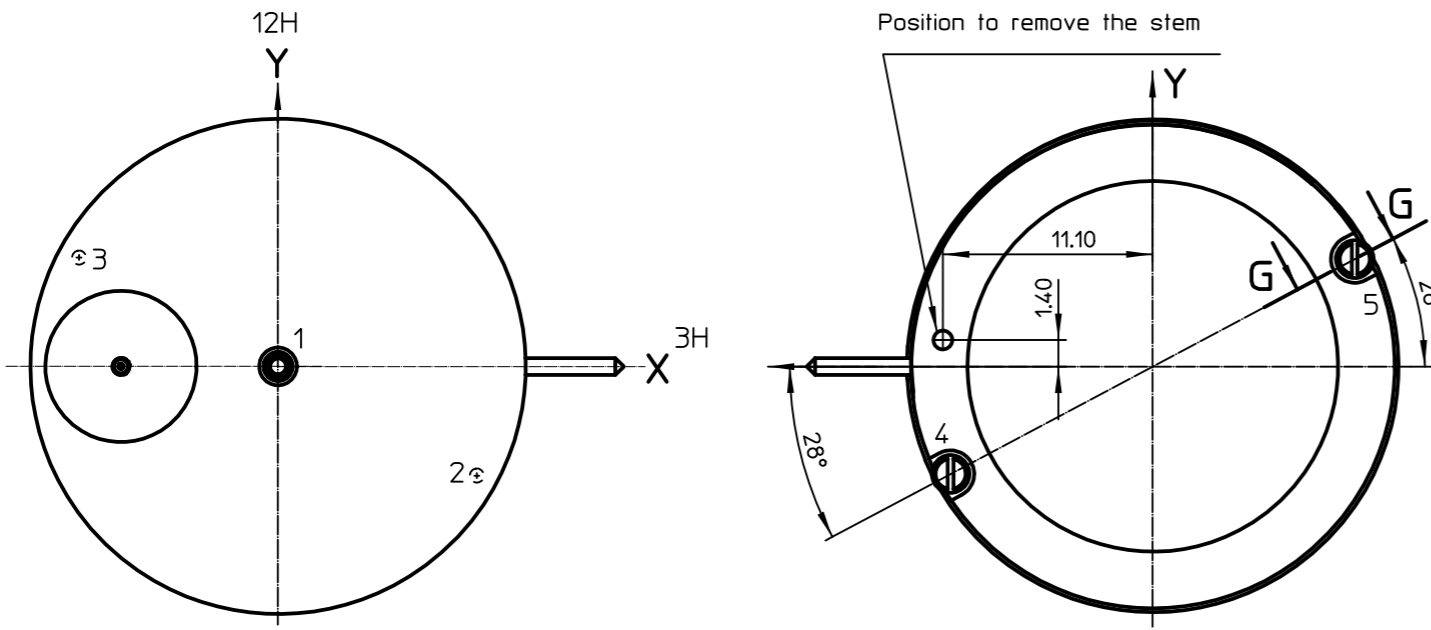
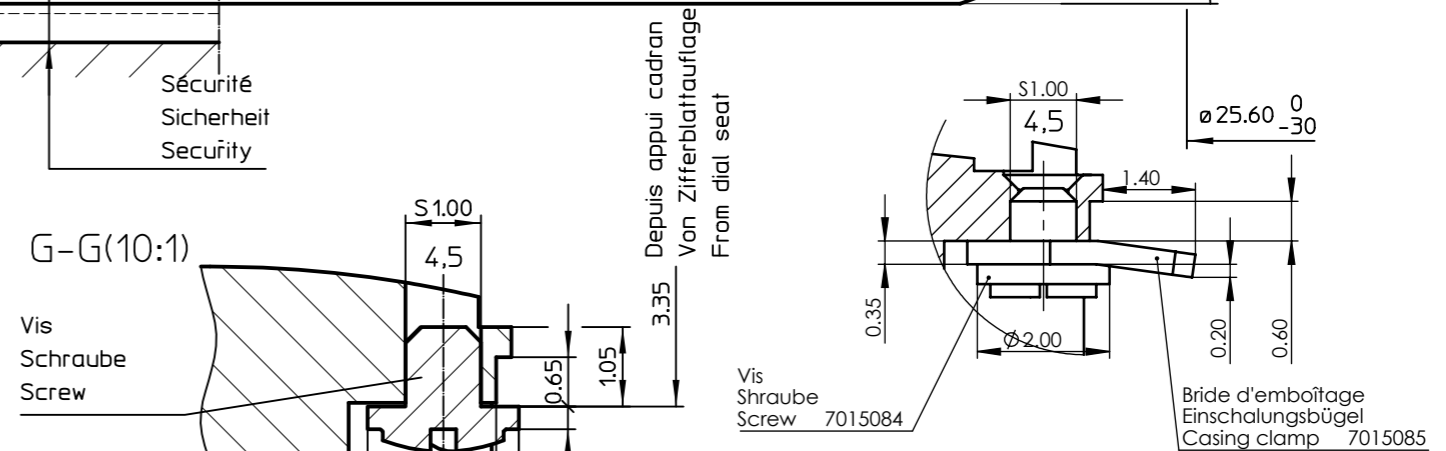
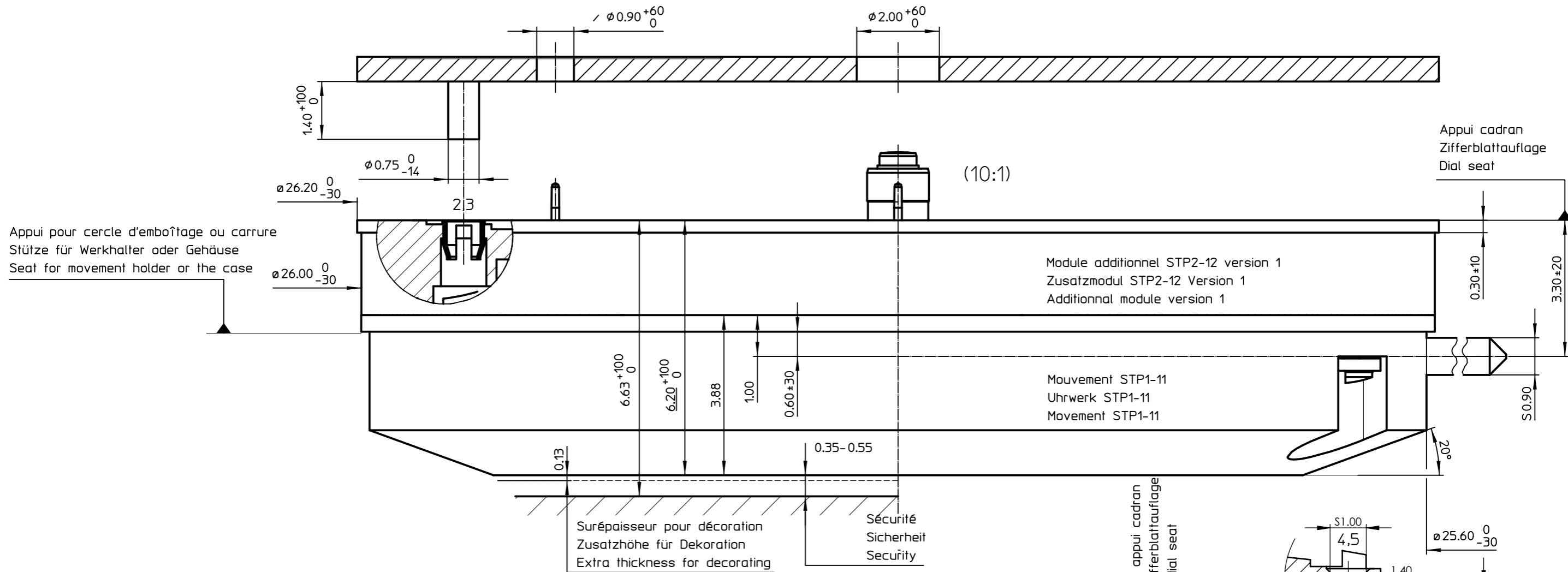

No	X	Y	X'
1	0.000	0.000	0.000
2	10.522	-5.770	-10.522
3	-10.522	5.770	10.522
4	10.684	-5.681	-10.684
5	-10.684	5.681	10.684

Calibre / Kaliber / Caliber STP2-12-12

MODIFICATIONS:

Heures et Minutes au centre,
 Petite seconde à 9H
 Stunden- und Minutenzeiger aus den Zentrum
 kleine Sekunde auf 9H
 Hours and Minutes central,
 small second at 9H

REMPLACE :
 REMPLACE PAR :

ECH. 2.5:1
 DESSINE 08.02.2019 STP/Gab
 COTES EN MILLIMETRES
 TOLERANCE EN MICRON

STP SWISS TECHNOLOGY PRODUCTION
 Cage pour boîte
 Uhrwerkstell für Gehäuse
 Frame for case

STP2-12-12.04.001.001A

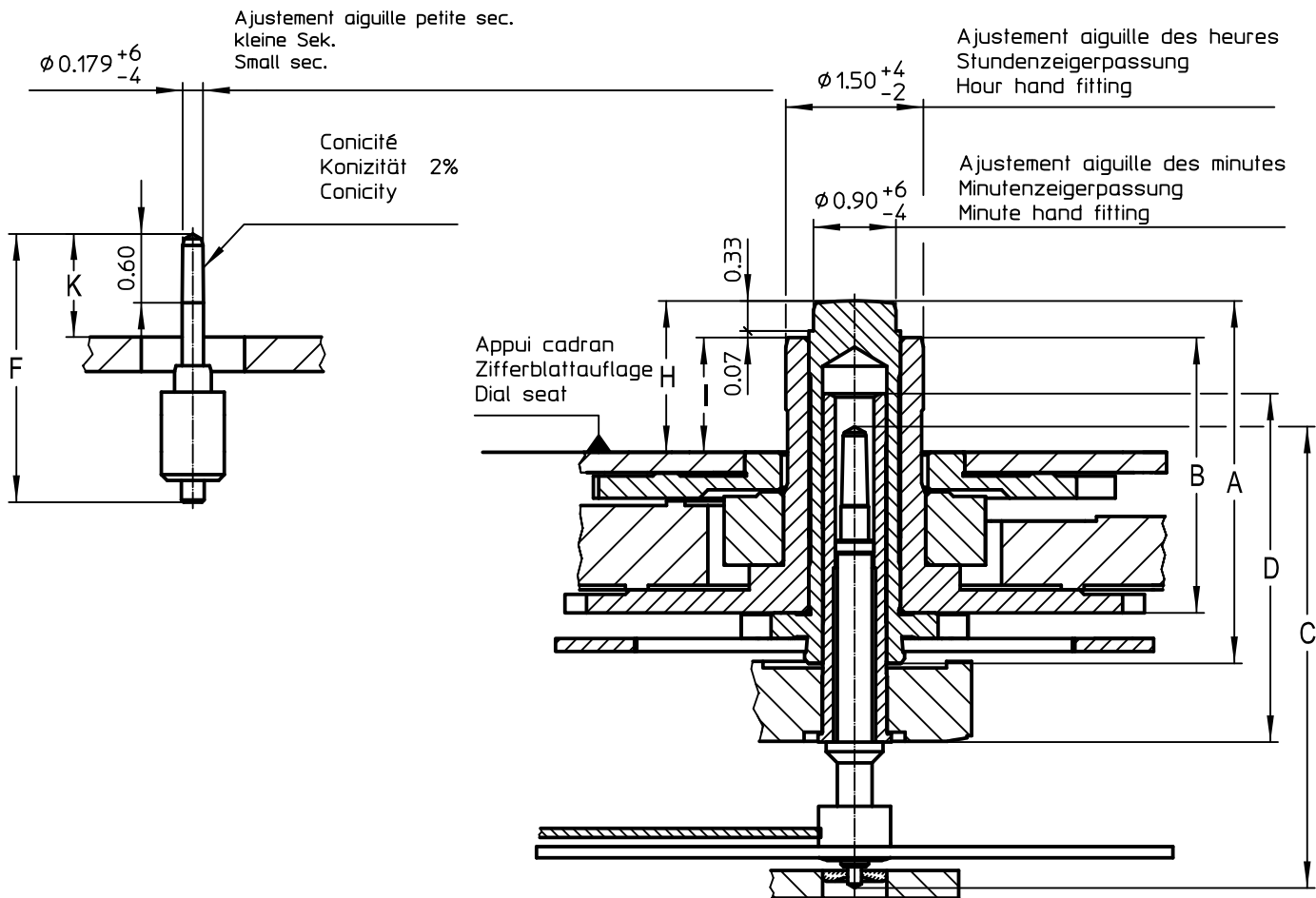

Aiguillage Zeigerwerkhöhe Hand fitting height	Dépassement / Höhe über Zifferblattaufgabe / Height over dial seat (mm)				Force de chargement Setzkraft / Press-in force (N)	Support mouvement nécessaire Unterstützung des Uhrwerk erforderlich Support for movement is needed
	H	I	K			
2 NORMAL	1.60	1.20	0.87		Max 40 ±5	Aiguille des heures Stundenzeiger Hours hand
					Max 40 ±5	Aiguille des minutes Minutenzeiger Minutes hand
					Max 20 ±3	Aiguille petite sec. Kleine Sek. Small sec.

Aiguillage Zeigerwerkhöhe Hand fitting height	Longueur / Länge / Length (mm)				
	A	B	C*	D	F
2 NORMAL	3.95	3.00	5.07	3.80	2.20

MODIFICATIONS:

REPLACE :

REPLACE PAR :

Calibre / Kaliber / Caliber ST2-12-12

ECH. DESSINE 08.02.2019 STP/Gab



Aiguillages
Zeigerwerkhöhen
Hand fitting heights

15:1

COTES EN MILLIMETRES

TOLERANCE EN MICRON

STP2-12-12.04.001.001C

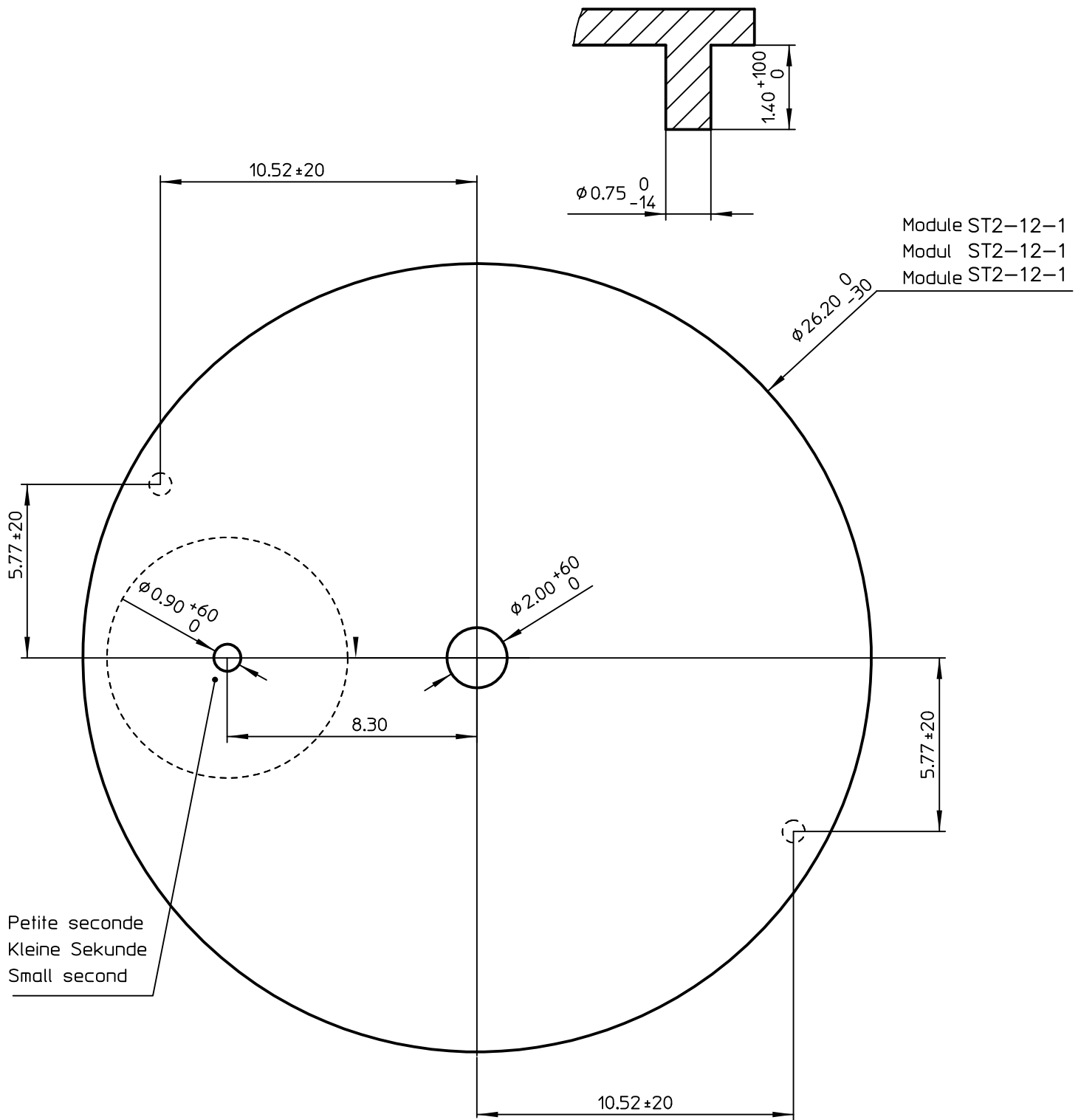

TRAITEMENT THERMIQUE		TRAITEMENT SURFACE		DURETE HV			
MODIFICATIONS:				REPLACE :			
Calibre / Kpliber / Caliber ST2-12-12				REPLACE PAR :			
	Indications pour cadran Angaben für Zifferblatt Indications for dial			ECH.	DESSINE	08.02.2019	STP/Gab
				5:1	COTES EN MILLIMETRES		
				TOLERANCE EN MICRON			
				STP2-12-12.04.001.001B			

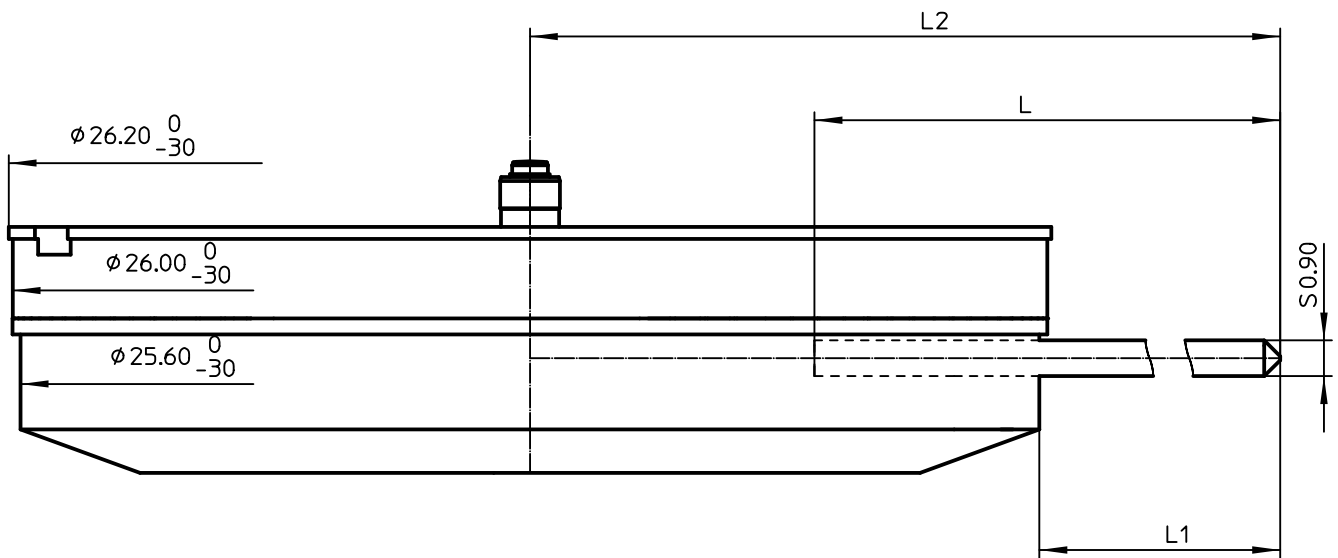

Longueur de tige Länge der Stellwelle Length of setting stem	L	L1	L2
Normal	16.00	8.65	21.65
Extra	18.00	10.65	23.65

* course de la tige: 0.8mm
weg der stellwelle: 0.8mm
length of travel stem: 0.8mm

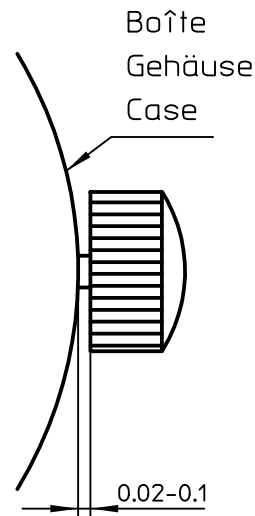

MODIFICATIONS:

REPLACE :

REPLACE PAR :

Calibre / Kaliber / Caliber: ST2-12-12

ECH. DESSINE 08.02.2019 STP/Gab

5:1 COTES EN MILLIMETRES

TOLERANCE EN MICRON



SWISS
TECHNOLOGY
PRODUCTION

Tige: Longueur et position couronne
Stellwelle: Länge und Kronenposition
Stem: Length and Crown position

STP2-12-12.04.001.001D

Test par remontage manuel du mécanisme d'automatique

En déposant le calibre / montre sur un plan incliné de °30, tourner manuellement la tige en sens horaire (remontage) entre 30 et 60 tous par minute.

Le rotor ne doit pas être entraînée et faire un tour. Le rotor peut balancer légèrement en restant en bas.

Handaufzugstes des Automakmechanismus

Bringen Sie den Kaliber / Uhr in eine °30 Position, drehen Sie manuell an der Aufzugskrone in die Aufzugs-richtung (nicht vor und zurück). Die geschwindigkeit soll zwischen 30 und 60 Umdreh-ungen pro minute liegen. Die Schwungmasse darf sich nicht in rotation versetzen lassen sandern nur leicht hin und her scwingen.

Manual winding test of automatic mechanism

Bring the caliber / watch in a °30 position, Manually turn the winding crown in the. The speed must de between 30 and 60 turns per minute.

The Oscillating weight should not be into rotation. However it may slightly swing.

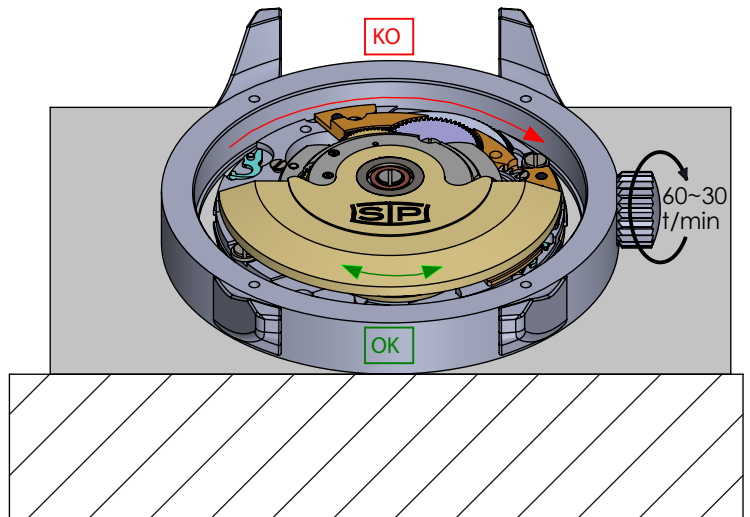
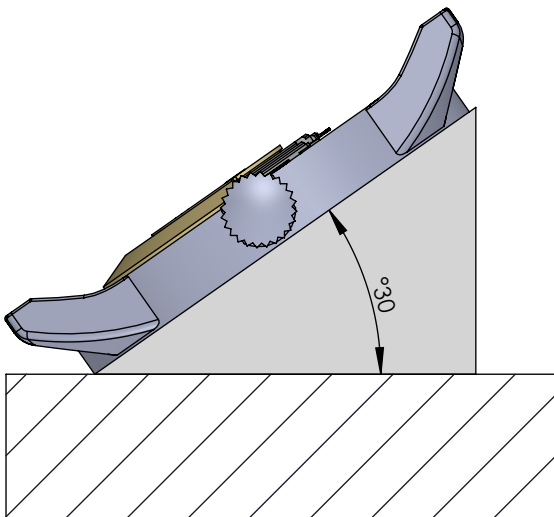

INFORMATIONS GENERALES

ALLGEMEINE INFORMTIONEN

GENERAL INFORMATION

Restrictions:

La correction rapide de la date(31)
n'est pas possible entre 21h et 01h

La correction rapide de la phase
de lune n'est pas possible entre
07h et 10h

Einschränkungen:

Schnelle Datumskorrektur (31)
is nicht möglich zwischen 21 Uhr und
01 Uhr.

Schnelle Mondphase Korrektur
ist nicht möglich zwischen
07h und 10h

Restrictions:

Quick date correction (31)
is not possible
between 09 p.m and 01 a.m

Quick Moon phase correction
is not possible between
07 a.m and 10 a.m

STP Swiss Technology Production SA
Rue des Places 13
CH-2855 Glovelier / Switzerland
Phone: +41 32 427 01 00
www.swisstp.com



Caliber: **STP2-12** (Séries)
(Reihe)
(series)

Created: 20.10.2019 Page: 1/1

Nous nous réservons tous les droits sur ce document. Il est confié au destinataire. Il ne peut, sans notre autorisation écrite, être copié, reproduit, communiqué à des tiers.
Für dieses Dokument behalten wir uns alle Rechte vor. Es ist nur für den Empfänger bestimmt. Ohne unsere schriftliche Bewilligung darf es nicht kopiert, vervielfältigt und Dritten zugänglich gemacht werden.
We reserve all rights for this document. It is meant for the recipient only and it may not be copied, printed or given to a third person without our written permission.

Force du ressort
 Federkraft
 Force of spring

FONCTION / FUNKTION / FUNCTION

max. 13N ←

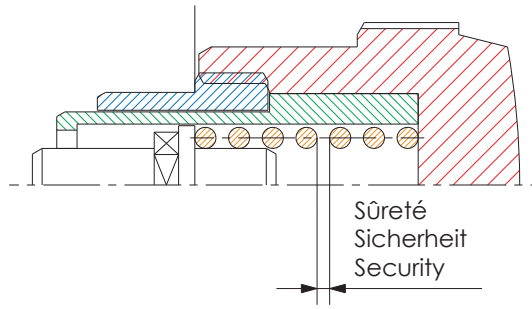

Couronne vissée
 Krone zugeschraubt
 Crown tightened

sans calendrier ohne kalender without calendar		avec calendrier mit kalender with calendar	
course de la tige weg der stellweg travel of setting stem		course de la tige weg der stellweg travel of setting stem	
C	0.80	C1	0.30
		C2	0.50

Sûreté
 Sicherheit
 Security

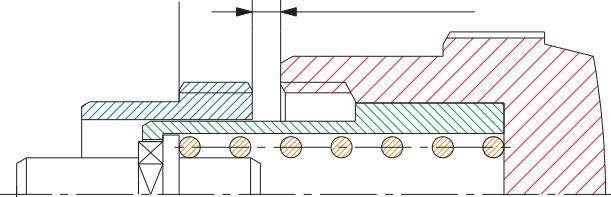

Remonter
 Aufziehen
 Wind up

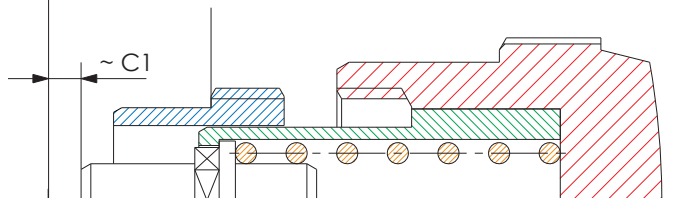

Correction date
 Datum einstellen
 Adjust date

$C = C1 + C2$

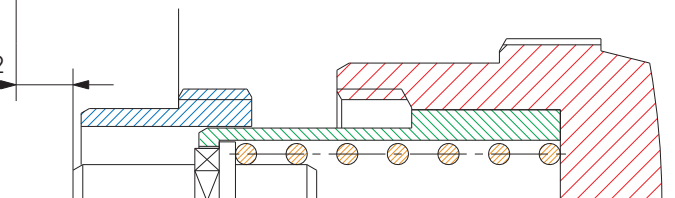

Mise à l'heure
 Zeiger stellen
 Adjust time

min. 9N ←

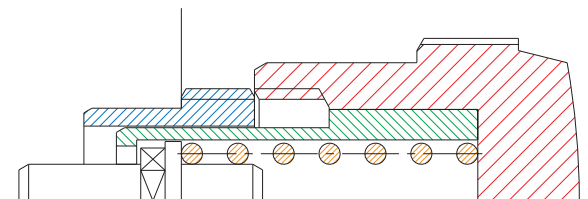

Position neutre
 Neutrale Stellung
 Neutral position

Calibre / Kaliber / Caliber

TOUT LES CALIBRES STP / ALLE STP KALIBER / ALL STP CALIBERS

REPLACE: *

ECH. 1:1	DESSINÉ	31.08.21	STP/Nor
	COTES EN MILLIMETRES		
TOLERANCES EN MICRONS			
S.WORKS	CODE ART:	*	



SWISS
 TECHNOLOGY
 PRODUCTION

COURONNE VISSÉE: POSITIONS
 GESCHRAUBTE KRONE: STELLUNGEN
 SCREWED CROWN: POSITIONS